

Key Features:

- 24 to 80VDC Supply Voltage
- H-Bridge, 2 Phase Bi-polar Micro-stepping Drive
- Suitable for 2-phase, 4, 6 and 8 leads step motors, with Nema size 23 to 42
- Output current selectable from 1.8 ~ 7.9A peak
- Current reduction by 50% automatically, when motor standstill mode is enabled
- Pulse Input frequency up to 200 kHz
- Optically isolated differential TTL inputs for Pulse, Direction and Enable signal inputs
- Selectable resolutions up to 12800 steps
- Over Voltage, Coil to Coil and Coil to Ground short circuit protection.

Introduction

PSD8079-2P is a cost effective, high performance bi-polar two phase micro-stepping drive applying pure-sinusoidal current control technique. It is best suited for the applications that desired extreme low noise and heat. It operates well in an environment, where electricity supply experience instability and fluctuation.

The general pseudo-sinusoidal current control technology adopted by majority of the drive produced distorted sine wave, and current ripple, resulting in vibration, noise and motor heating. This results in motor degrading over time, reducing in motor performance and shortens the usage life.

With an automatic optimization speed control technique, the PowerStep series drive output is very stable, with almost zero vibration and noise, performing close to a servo system, allowing the motor to operate smoothly. That helps to fulfill a design requirement of low noise, low heat and high performance.

Specifications

Parameters	Min	Typical	Max	Unit
Output Current (Peak)	1.8	-	7.9	Amps
Supply voltage	24	48	80	VDC
Logic Input Current	7	10	16	mA
Pulse input frequency	0	-	200	KHz
Low Level Time	2.5			µsec

Cooling	Natural Cooling or Forced Convection	
Environment	Space	Avoid dust, oil frost and corrosive gases
	Ambient Temperature	0°C – 50°C
	Humidity	40 – 80%RH
	Vibration	5.9m/s ² Max
Storage Temp.	-10°C – 80°C	
Weight	Approx. 500 gram	

Mechanical Dimensions (mm)

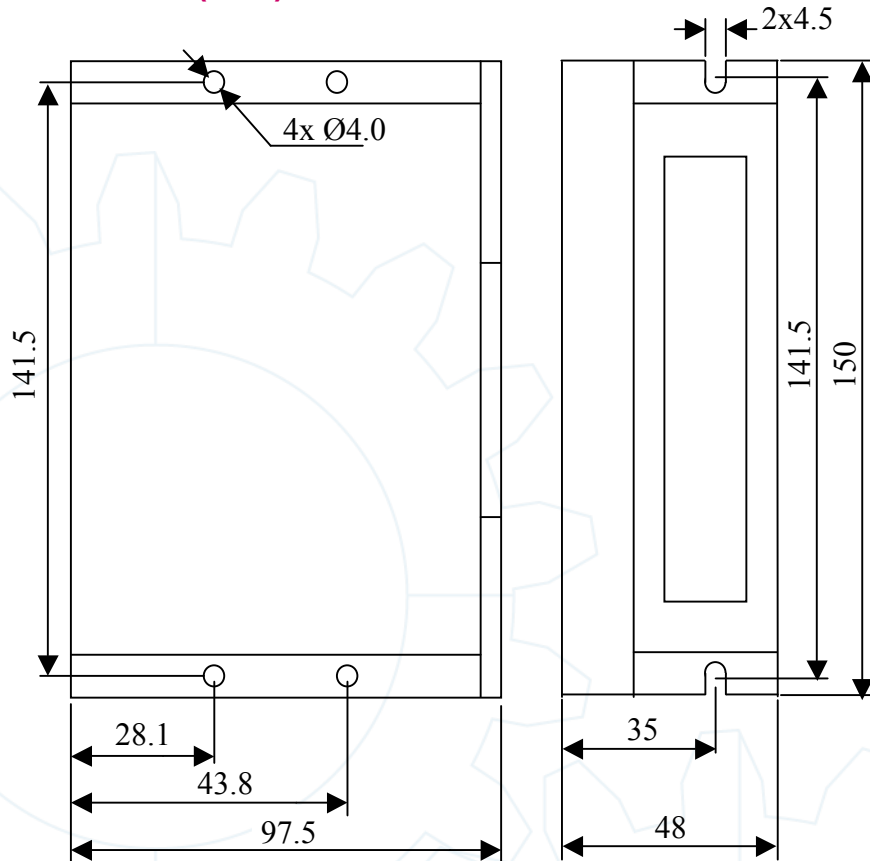

Current Setting

Current Setting (A)	SW1	SW2	SW3
1.8	OFF	OFF	OFF
2.5	ON	OFF	OFF
3.5	OFF	ON	OFF
4.3	ON	ON	OFF
5.2	OFF	OFF	ON
6.0	ON	OFF	ON
7.0	OFF	ON	ON
7.8	ON	ON	ON

Microstep Setting

Step / Rev	SW5	SW6	SW7	SW8
200	OFF	OFF	OFF	OFF
400	ON	OFF	OFF	OFF
500	OFF	ON	OFF	OFF
800	ON	ON	OFF	OFF
1000	OFF	OFF	ON	OFF
1250	ON	OFF	ON	OFF
1600	OFF	ON	ON	OFF
2000	ON	ON	ON	OFF
2500	OFF	OFF	OFF	ON
3200	ON	OFF	OFF	ON
4000	OFF	ON	OFF	ON
5000	ON	ON	OFF	ON
6400	OFF	OFF	ON	ON
8000	ON	OFF	ON	ON
10000	OFF	ON	ON	ON
12800	ON	ON	ON	ON

* SW4: ON=Full current, SW4 : OFF=Half current

P1 Terminal Assignment

Signal	Function and Descriptions
PUL+	<u>Pulse or Step Input</u> TTL differential input with high-going pulse, 1 μs min width. For +12V or +24V operation, a current limiting resistor had to be pull up or connected in series from the PUL+ to the VCC.
PUL-	
DIR+	<u>Direction Input</u> Logic High = positive (CW) rotation—4.0 ~ 5.0V Logic Low = negative (CCW) rotation—0 ~ 0.5V
DIR-	The DIR signal must be stable for at least 5ms before the drive receives the first pulse.
ENA+	<u>Enable Input</u> Logic High = Drive Enabled Logic Low = Drive Disabled
ENA-	This input, if left unconnected, is recognised as Logic High by the drive, and it will be enabled.

P2 Terminal Assignment

P2 Signal	Function and Descriptions
GND	DC Power Ground
+V	DC Power Supply, +24VDC ~ +80VDC
A+, A-	<p>4 Leads Motor Full Coil Half Coil</p>
B+, B-	<p>Series Parallel</p> <p>8 Leads Motor</p>

Wiring

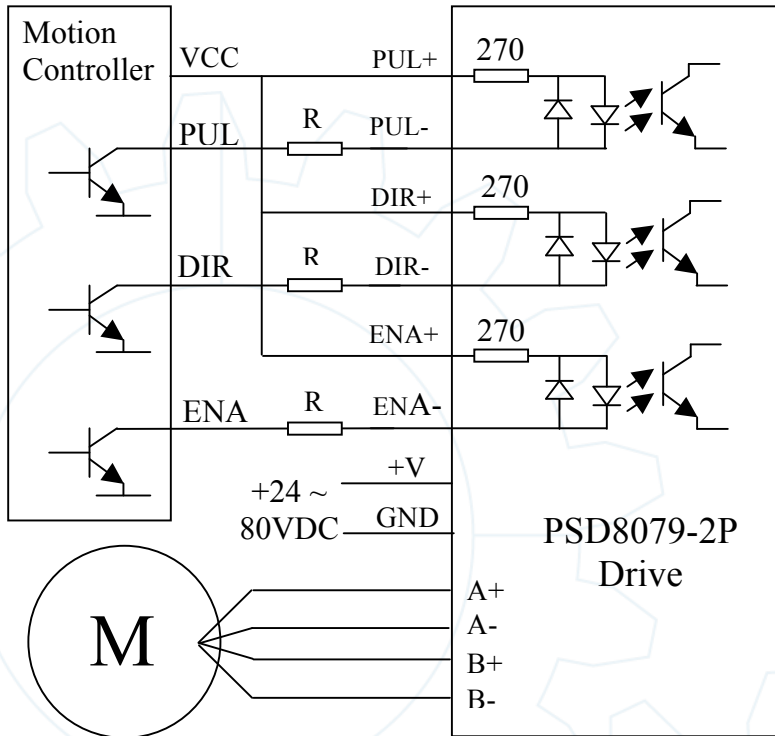

R=0 if VCC=5V
 R=1K(Power>0.125W) if VCC=12V;
 R=2K(Power>0.125W) if VCC=24V;
 R must be connected to control signal terminal.